

# Series CZ and CN Zero Backlash Safeguard Overload Clutch



Zero backlash Overload Clutches and Couplings, series CZ and CN, available in 8 different basic types, and 12 basic sizes, for shaft diameters from 8mm to 60mm; providing Overload Protection for Torque values from 5Nm to 740Nm.

The CZ series Safeguard overload clutches were developed to provide a totally backlash free transmission of power with a very responsive overload protection. These compact units are directly interchangeable with existing designs in the market providing a cost advantage with long reliable service life.

Two basic modes of operation are available, the basic CZF/CNF Safeguard ratchetting design with the driving balls equally spaced so that clutch can re-engage after a small angle of rotation, and the Synchron CZY/CNY design with the balls unequally spaced so that clutch can only re-engage after a full revolution so providing full synchronisation between driver and driven. Responsive overload reaction is obtained by the use of negative functioning Disc Springs to apply drive load. In the event of an overload the spring load actually decreases, allowing faster dis-engaging of the drive, and minimal pressure on the driving surface in the dis-engaged mode, reference diagrams below.



Tel : +44 121 360 0155

Fax : +44 121 325 1079

Email : sales@crossmorse.com

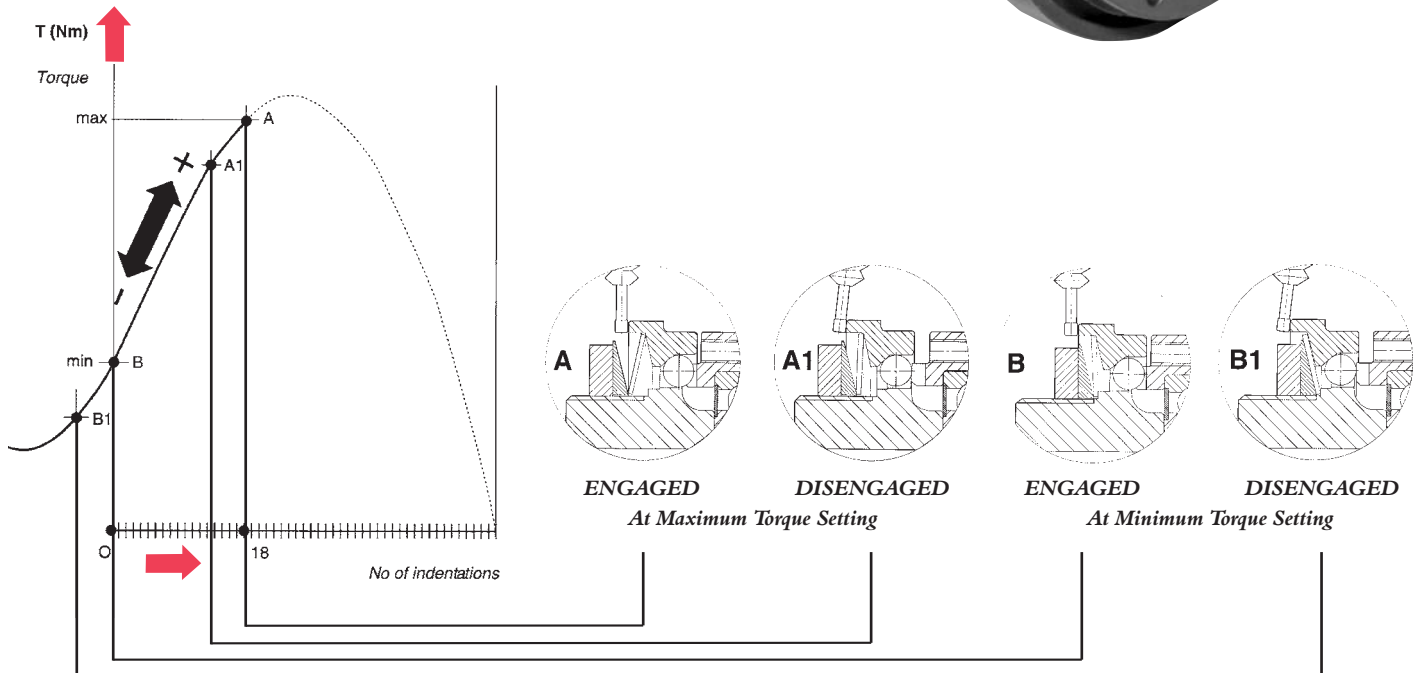

## Method of Operation

During normal operation the CZ/CN Overload Clutches transmits the torque from the Hub (1) to the Flange (3) by a number of hardened steel balls (4) located in pockets in the Hub, and forced into matching seats in the Flange by the Disc Spring (6) applying load to the Pressure Flange (2).

In the event that the Driving Torque exceeds the pre-set value, the reaction forces on the Steel Balls exceeds the force applied by the Pressure Flange, and the Balls start to ride-up out of their seats in the Flange (3). This action reduces the spring load, so allowing the Balls to quickly come out of their seats, so releasing the drive. The action of the Balls dis-engaging moves the Pressure Flange to the right so activating the stop switch (9).

Re-engagement is automatic once the torque level drops below the pre-set value. The Synchron design re-engages only at one angular position to keep Hub and Flange accurately synchronised at all times.

The Disc Springs work only in the negative area of their characteristics so unscrewing the Adjusting Nut (7) increases the axial load of the Springs, so increasing dis-engaging torque. When desired Torque setting is achieved the Adjusting Nut is locked by the Bolt (8) being screwed into the locking Collar (10).

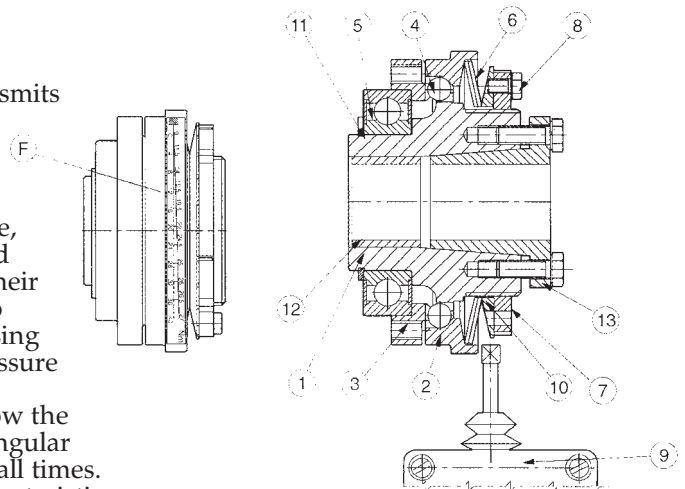

# Series CZ and CN Safeguard Overload Clutch



## CZ/CN Series Clutches and Couplings Torque Adjustment

Referring to drawing alongside Torque setting of the Clutches can be made using either a suitable size 'C' Spanner (A), or a correct size Pin Wrench (C). First release Adjusting Nut (7) by removing the Locking Screw (8), then rotate the Nut clockwise until at end of stroke (do not apply excess force). Then rotate nut back anti-clockwise by one indent to reach the neutral position, corresponding to minimum torque. Then continue to turn Adjusting Nut anti-clockwise for the number of indents indicated on the label (F) on the outside of Clutch for required Torque. Put Threadlock on Locking Screw, and replace in one of the threaded holes (G) which aligns with a hole in the Locking Plate behind.

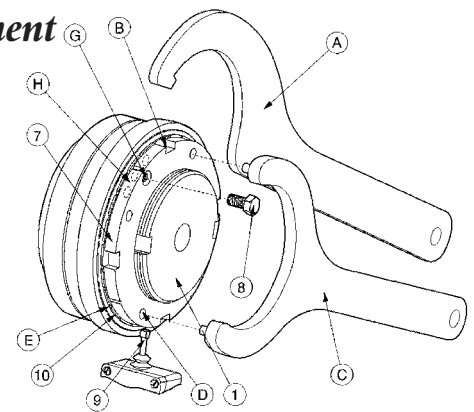

## Overload Sensor Switches

It is strongly recommended that all installations should include a Limit Switch or Sensor to switch off the power in event of an overload. The following are standard units available with mounting instructions.

Tel: +44 121 360 0155

Fax: +44 121 325 1079

Email: sales@crossmorse.com

a) Proximity Sensor Switch for Radical mounting - CSS3

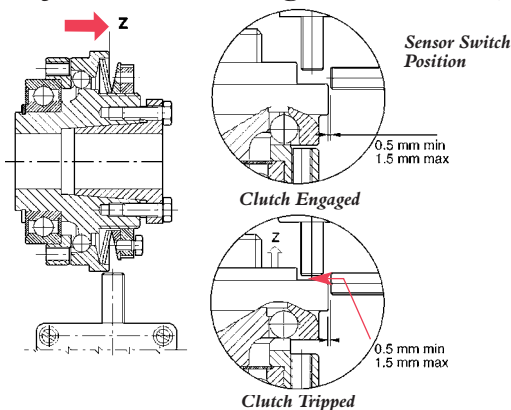

a) Proximity Sensor Switch for Axial movement - CSS4

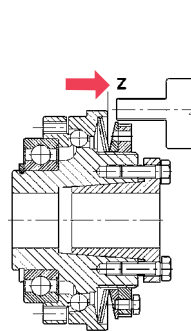

a) Mechanical Limit Switch for contact actuation - CSS1

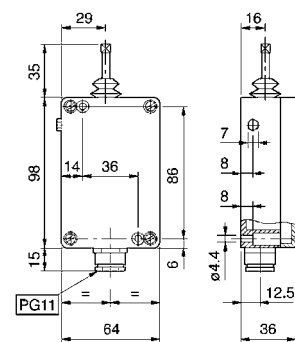
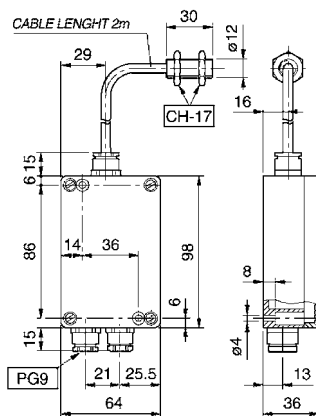
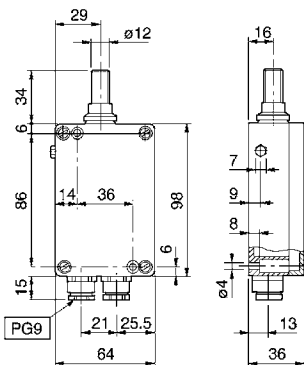
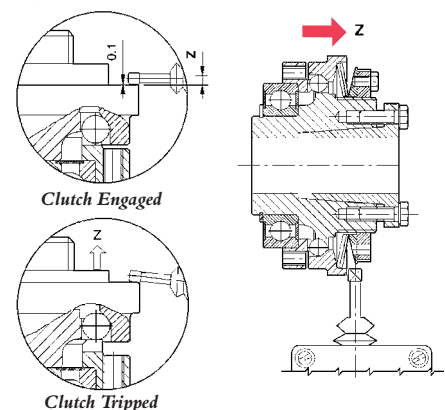

### Outer Movement in Overload

CS CLUTCH	Z mm				R	CZ/ CN	z mm
	CFS	CSY	CSL	CSZ			
20	1.4	1.2	0.6	1.6	-	11	0.8
25	2.3	1.8	0.8	2.3	-	16	1.0
35	2.4	2.0	1.1	3.0	-	20	1.2
45	2.7	2.2	1.2	3.5	-	25	1.2
55	3.7	2.5	1.2	3.8	2.5	30	1.5
65	4.6	3.0	1.6	4.5	3	40	1.8
80	5.0	3.5	2.5	-	3.5	50	2.0
100	5.5	4.0	2.7	-	4	60	2.2

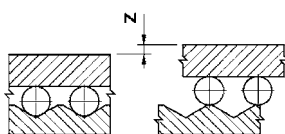

For other clutch types refer to respective dimension tables.

### Wiring Connections for Proximity Sensor - Models CSS3 & CSS4

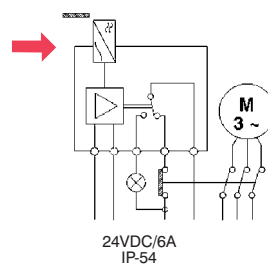

### Wiring for Limit Switch Model CSS1

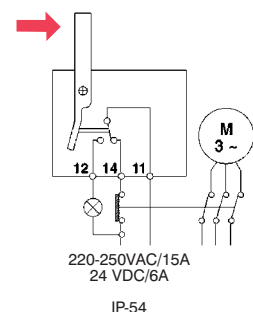

# Series CZ Safeguard Overload Clutches Standard Plain Bore Units



## Standard Zero Backlash Clutches types H&K

These clutches are intended for keyway connection to shafts where pre-machined synchronisation is the preferred design. Type H is used to mount compact drive systems with minimal overhung load, the single deep groove ball bearing providing full radial support for the sprocket, pulley, or gear.

Type K has an extended inner race to support a second Bearing to allow fitment of wider transmission elements, and where high radial loads may be encountered.

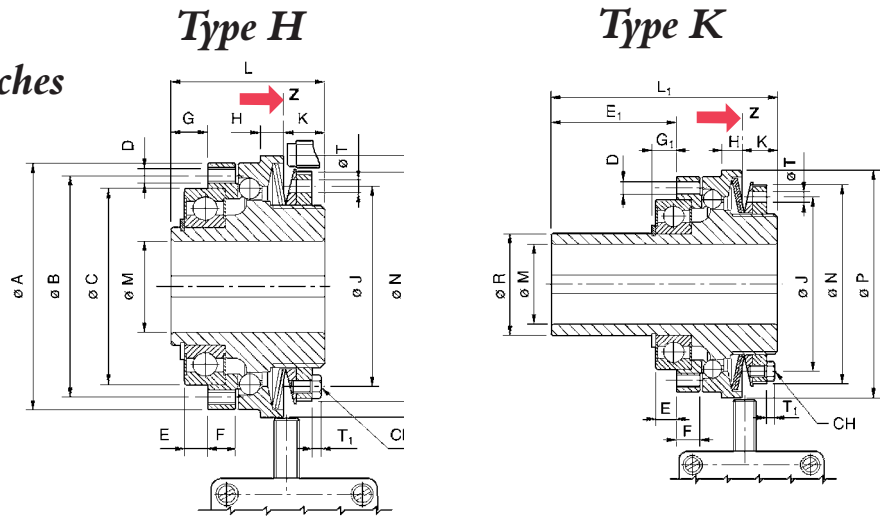

## CZ Series types H & K - Technical Capacities

Models H&K Clutch Size	Torque Range according to Spring selection			Max.Speed rpm	Bore Size 'M'		Weight kg		Hub Inertia kgcm <sup>2</sup>		Flange Inertia kg m <sup>2</sup>
	S Nm	M Nm	U Nm		min mm	max mm	Type H	Type K	Type H	Type K	
25	3-14	6-28	13-56	4000	8	20	0.74	0.83	2.15	2.22	0.95
30	9-35	18-70	40-140	3000	10	30*	1.37	1.41	5.30	5.58	2.35
40	19-65	38-130	78-260	2500	14	35*	2.28	2.56	13.68	14.58	6.45
50	35-110	80-220	160-440	2000	18	45*	3.29	3.74	27.62	29.88	13.07
60	80-185	160-370	320-740	1200	24	50	5.12	5.73	66.45	72.01	26.52

\*For clutch Part No. for ordering refer bottom of page

\*max bore achievable only with keyway according to DIN 6885 Sheet 3

## CZ Series types H & K - Dimensions

Clutch Size	A	B	C h5	D	E	E <sub>1</sub>	F	G	G <sub>1</sub>	H	J	K	L	L <sub>1</sub>	M		N	P	R h6	T	T <sub>1</sub>	Z	CH A/F
															min	max							
25	65	56	47	8x M4	5	33	7.5	8	6.5	7	54.5	12	40	65	8	20	63	70	30	5	2.8	1.2	7
30	80	71	62	8x M5	7	43	8.0	11	8.8	8	69.0	14	48	80	10	30*	77	85	40	5	2.8	1.5	7
40	95	85	75	8x M6	9	55	10.5	14	11.5	9	77.0	16	59	100	14	35*	88	100	45	5	3.5	1.8	8
50	110	100	90	8x M6	10	67	12.0	16	13.0	10	87.5	17	64	115	18	45*	100	115	55	6	4.0	2.0	10
60	130	116	100	8x M8	10	73	12.0	18	14.0	12	106.0	21	75	130	24	50	122	135	65	7	4.0	2.2	10

For Limit Switch location and operation refer to page 29. Always use limit switch for long service life.

## Clutch Part Numbers for Ordering

To correctly order CZ series clutches it is essential to identify the clutch operating mode, size, type, spring ratings (torque range), and for clutches and couplings using Clamping Elements for shaft connection, the shaft diameters.

**Operating Mode:** CZ series clutches are available with two operating modes, ratchetting type CZF for applications where synchronisation of input to output is not required, and single position type CZY for full synchronisation.

**Clutch Size:** The clutch size generally indicates the max bore size, and is identified in the tables.

**Clutch Type:** A letter from H to T indicates the clutch/coupling design, as shown in the respective drawings.

For couplings type M and N it is required to indicate the coupling size also, e.g. for Coupling size 40-72 type M the reference is M72, for couplings P,R & T it is necessary to indicate rubber shore value ie. P92 is with rubber 92 shore.

Spring Rating: following a / the letter S, M, or U indicates the Spring sizes selected, which controls the torque range.

**Bore Sizes:** Except for pilot bored types H, K and M it is essential that the finish bore sizes of the Clutch/Coupling are provided to enable supply of the unit. Types H, K and M can be supplied with finish bores also if specified.

## Examples

CZF40H/M

is a Ratchetting size 40 clutch type 'H' with spring selection M.

CZY50L/S-40

is a Synchronous size 50, type L, with spring set S, fitted with 40mm clamping bush.

CSY40N89/U-35/40

is a Synchronous Coupling size 40, type N, with spring set U, with the clutch half fitted with a 35mm clamping bush, and the coupling half with a 40mm clamping bush.

CSY50M89/S-38/48

is a Synchronous Coupling size 50, type M, with spring set S, with the clutch half bored and keyed for a 38mm shaft, and the coupling half bored and keyed for 48mm.

# Series CZ Safeguard Overload Clutches



## Standard Units With Expanding Bush Shaft Connection

Zero Backlash Clutch for keyless shaft connection types J & L. These clutches provide totally backlash free connection of drive gears and sprockets to shafts. A selection of clamping inserts provides a wide range of shaft diameters to be accommodated. Type J can be used to mount compact drive systems, with minimal overhung load, the single deep groove ball bearing providing full radial support.

Type L has extended inner race to support a second bearing to enable fitting of wider transmission elements.

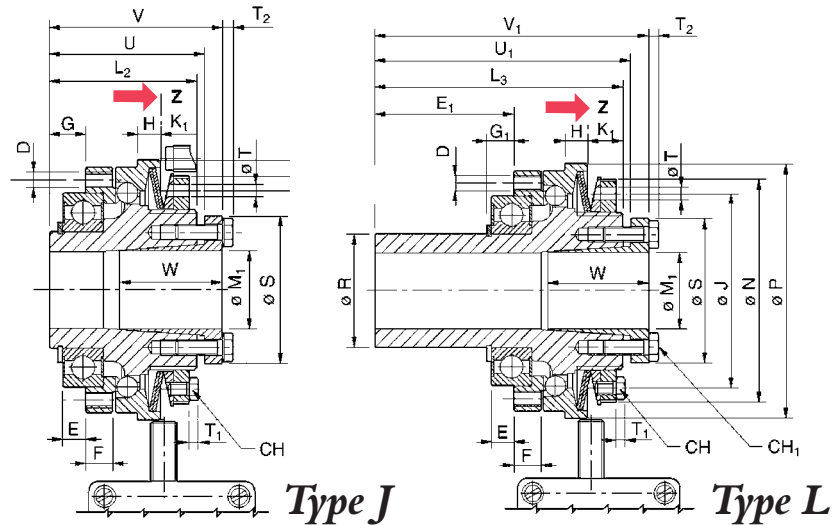

### CZ Series types J & L - Technical Capacities

Models* J & L Clutch Size	Torque Range according to Spring selection			Max.Speed rpm	Bore Size 'M1'		Weight kg		Hub Inertia kgcm2		Flange Inertia kgcm2
	S Nm	M Nm	U Nm		min mm	max mm	Type J	Type L	Type J	Type L	
25	3-14	6-28	13-56	4000	10	25	0.72	0.81	2.29	2.36	0.95
30	9-35	18-70	40-140	3000	15	30	1.26	1.50	5.90	6.17	2.35
40	19-65	38-130	78-260	2500	19	40	2.11	2.39	14.75	15.66	6.45
50	35-110	80-220	160-440	2000	32	50	2.98	3.43	30.34	32.60	13.07
60	80-185	160-370	320-740	1200	32	60	4.75	5.36	71.94	77.18	26.52

\*For clutch Part No. for ordering refer to page 30.

### CZ Series types J & L - Dimensions

Clutch Size	A	B	C h5	D	E	E1	F	G	G1	K1	L2	L3	M1 min max	P	R h6	S	T2	U	U1	V	V1	W	Z	CH1 A/F	
25	65	56	47	8x M4	5	33	7.5	8	6.5	12	40	65	10 19	20 25	70	30	40.5 42	2.8	42	67	47	72	26.5 26	1.2	7
30	80	71	62	8x M5	7	43	8.0	11	8.8	12	46	78	15 30	85	40	57	4	49	81	56	88	31	1.5	10	
40	95	85	75	8x M6	9	55	10.5	14	11.5	14	57	98	19 32	30 40	100	45	57 64	4 3.5	60	101	67	108	40 31	1.8	10 8
50	110	100	90	8x M6	10	67	12.0	16	13.0	16	63	114	32	50	115	55	73.5	4	66.5	118	73	124	29	2	10
60	130	116	100	8x M8	10	73	12.0	18	14.0	21	75	130	32 55	50 60	135	65	73.5 89	4	78.5 78	134 133	85 86	140 141	29 45.5	2.2	10

For Limit Switch location and operation refer to page 29. Always use limit switch for long service life.

### Standard Bore sizes available on J & L type clamping hubs, with respective maximum transmittable Torques

Clutch Size	Available Bore sizes in mm (Figures indicate max. transmittable Torque Nm)																			Bolt Torque Nm						
	10	11	12	14	15	16	18	19	20	22	24	25	28	30	32	35	38	40	42		45	48	50	55	60	
25	65	70	75	90	95	100	115	120	130	140	150	160														3
30					120	130	150	160	180	190	210	220	240	260												10
40								240	260	290	310	320	360	390												10
40															440	480	520	550								5.9
50															620	680	730	770	810	870	930	970				10
60															620	680	730	770	810	870	930	970	1070	1160		10

Shaft tolerance required for correct operation is h6 up to 40mm dia., h7 for over 40mm.

### Typical Mounting Arrangements with Timing Pulleys

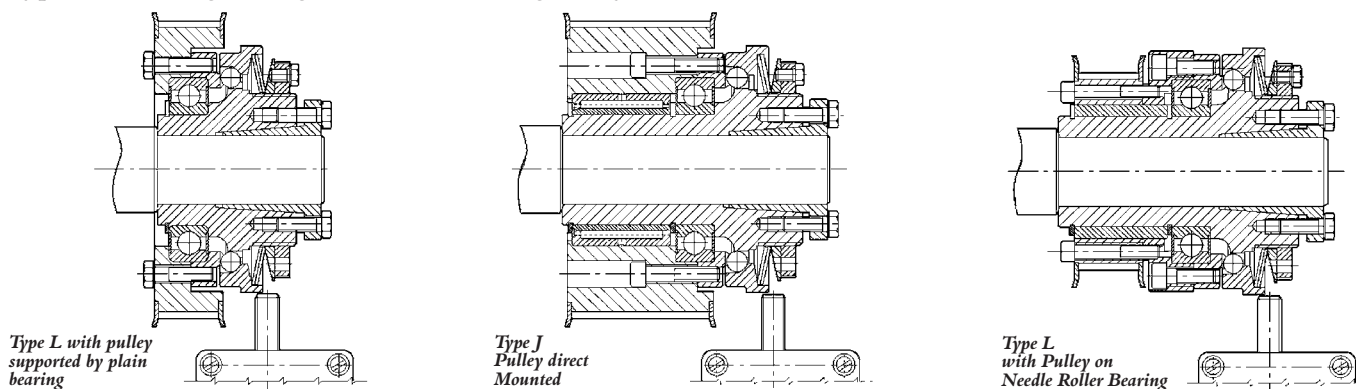

Type L with pulley supported by plain bearing

Type J Pulley direct Mounted

Type L with Pulley on Needle Roller Bearing

Tel : +44 121 360 0155

Fax : +44 121 325 1079

Email : sales@crossmorse

# Series CZ Safeguard Overload Couplings



Standard CZ series Zero Backlash Overload Clutches combined with a Torsionally stiff. Steel Disc Coupling for ultimate shaft to shaft positional accuracy, with full overload protection. Available with keyed shaft connection, or totally keyless with shaft clamping elements.

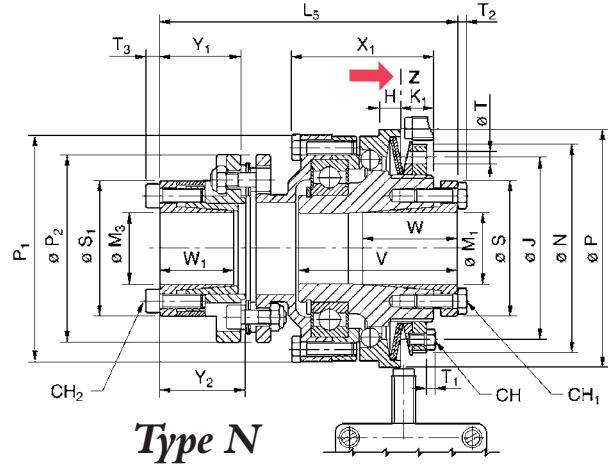
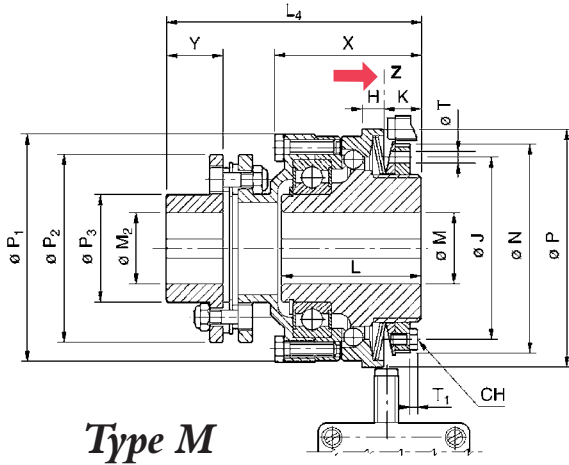

## CZ Series Couplings types M & N - Technical Capacities

Models M & N Coupling Size	Torque Range According to Spring Type			Speed Max. rpm	Coupling Type M Bore Sizes				Coupling Type N Bore Sizes				Weight		Hub Inertia		Flange Inertia		Max. Misalignment Coupling	
	S Nm	M Nm	U Nm		Clutch Hub		Coupling Hub		Clutch Hub		Coupling Hub		Type M kg	Type N kg	Type M kgcm <sup>2</sup>	Type N kgcm <sup>2</sup>	Angular degrees	Axial mm		
	M min mm	M max mm	M2 min mm		M2 max mm	M1 min mm	M1 max mm	M3 min mm	M3 max mm	Type M kg	Type N kg	Type M kgcm <sup>2</sup>	Type N kgcm <sup>2</sup>	Angular degrees	Axial mm					
25-53	3-14	6-28	13-56	4000	8	20	6	25*	10	25	11	20	1.2	1.2	2.15	2.22	2.42	2.47	1	0.4
30-72	9-35	18-70	40-140	3000	10	28	10	35	15	30	19	30	2.4	2.0	5.30	5.58	6.92	7.06	1	0.5
40-72	19-65	38-130	78-260	2500	12	35*	10	35	19	40	19	30	3.5	3.4	13.68	14.58	16.55	16.88	1	0.5
40-89	19-65	38-130	78-260	2500	12	35*	14	50*	19	40	24	42	4.3	3.6	13.68	14.58	16.55	26.12	1	0.6
50-89	35-110	80-220	160-430	2000	16	45*	14	50*	32	50	24	42	5.5	4.8	27.62	29.88	34.03	34.71	1	0.6
60-118	80-185	160-370	320-740	1200	22	50	15	65	32	60	32	60	9.4	7.8	66.45	72.01	43.52	44.39	1	0.8

For clutch Part No. for ordering refer to page 30.

\*max bore achievable only with keyway according to DIN 6885 Sheet 3

## CZ Series Couplings types M & N - Dimensions

Models M & N Size	Dimensions																									
	K	K1	L	L4	L5	L8	N	P	P1	P2	P3	S MAX	S1 MAX	T1	T2	T3	V	W MIN	W1 MIN	X	Y MAX	Y1 MAX	Z	CH	CH1	CH2
25-53	12	12	40	87.5	95.5	28	63	70	65	53	32	42	42	2.8	2.8	4	47	26	26.5	41.5	24.5	25.5	1.2	7	7	3
30-72	14	12	48	113.0	114.5	34	77	85	80	72	47	57	58	2.8	4.0	6	56	31	31	50.0	39.5	33.0	1.5	7	10	5
40-72	16	14	59	126.5	128.0	43	88	100	97	72	47	57	58	3.5	4.0	6	67	40	31	62.0	39.5	33.0	1.8	8	10	5
40-89	16	14	59	142.5	150.0	43	88	100	97	89	62	64	72	3.5	3.5	6	67	31	45	62.0	45.0	44.5	1.8	8	8	5
50-89	17	16	64	145.0	153.5	47	100	115	111	89	62	74	72	4.0	4.0	6	73	29	45	66.5	45.0	44.5	2.0	10	10	5
60-118	21	21	75	172.5	172.5	54	122	135	131	118	82	89	92	4.0	4.0	6	86	29	29	76.5	55.0	44.0	2.2	10	10	5

## Standard Bore sizes available on N type Clutch clamping hubs, with respective maximum transmittable Torques

Clutch Size	Available Bore sizes in mm (Figures indicate max. transmittable Torque Nm)																				Bolt Torque Nm						
	10	11	12	14	15	16	18	19	20	22	24	25	28	30	32	35	38	40	42	45		48	50	55	60		
25	65	70	75	90	95	100	115	120	130	140	150	160														3	
30					120	130	150	160	180	190	210	220	240	260													10
40								240	260	290	310	320	360	390													10
40															440	480	520	550									5.9
50															620	680	730	770	810	870	930	970					10
60															620	680	730	770	810	870	930	970	1070	1160			10

## Standard Bore sizes available on N type Coupling half clamping hubs, with respective maximum transmittable Torques

Clutch Size	Available Bore sizes in mm (Figures indicate max. transmittable Torque Nm)																	Element Bolt Torque Nm	Disc Bolt Torque Nm									
	11	12	14	15	16	18	19	20	22	24	25	28	30	32	35	38	40			42	45	48	50					
25-53	80	87	102	108	116	130	138	145																		5	6	
30-72				146	155	175	210	220	242	265	276	309	331														17	8
40-72							210	220	242	265	276	309	331														17	8
40-89										529	552	618	662	706	772	839	883	926									17	15
50-89										529	552	618	662	706	772	839	883	926									17	15
60-118														730	798	866	912	958	1026	1094	1140						17	33

Shaft tolerances required for correct operation is h6 up to 40mm dia., h7 for over 40mm., for both Clutch and Coupling Disc Bolt Torque is for the bolts on the Flexible Disc Plate

# Series CZ Safeguard Overload Couplings



## Standard Keyless Connection Overload Clutches with Elastomeric Couplings

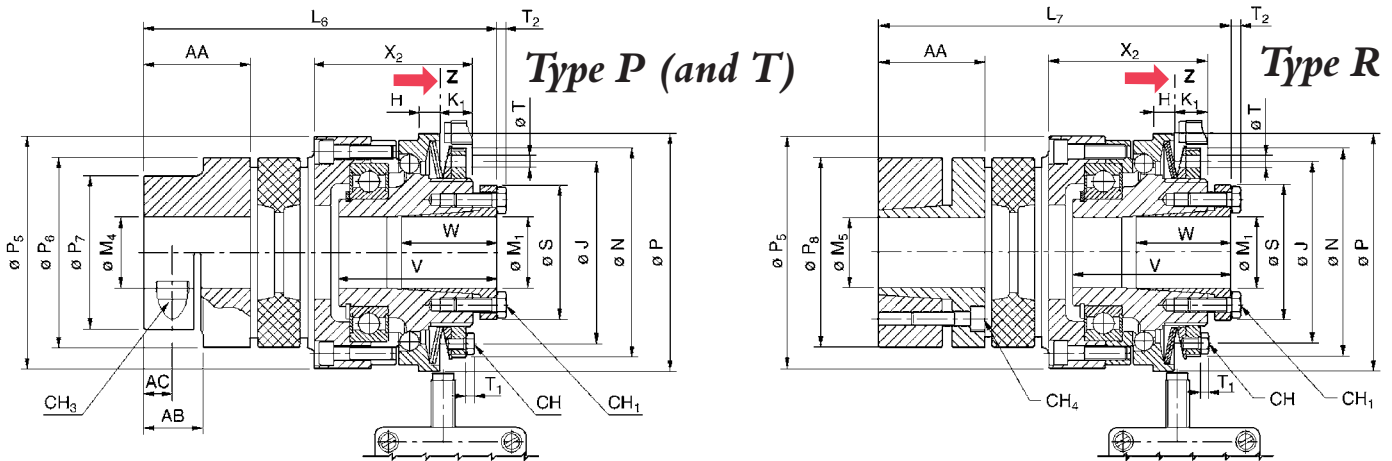

Couplings type T is identical to type P except coupling hub is not split, and hub suitable for standard reworking  
Couplings are supplied standard with 92 Shore rubber inserts, but 98 shore can be supplied to order

### CZ Series Couplings types P, R & T - Technical Capacities

Models P, R & T Clutch Size	Torque Range According to Spring Type			Nominal Torque Flexible Coupling		Speed Max. rpm	Clutch Hub Bore Sizes*		Coupling Hub Bore Sizes*						Weight		Hub Inertia kgcm2	Flange Inertia kgcm2	Max. Misalignment of Coupling				
	S Nm	M Nm	U Nm	92 Sh.A Nm	98 Sh.A Nm		M1 min mm	M1 max mm	Cplg Types P & T			Cplg Type R			Type P & T kg	Type R kg			Axial mm	92 Shore A		98 Shore A	
									M4 min mm	M4 (P) max mm	M4 (T) max mm	M5 min mm	M5 max mm	Radial mm						Ang. deg.	Radial mm	Ang. deg.	
25	3-14	6-28	13-56	70	120	4000	10	25	10	28	28	15	28	1.38	1.53	2.2	4.00	1.4	0.14	1	0.10	0.9	
30	9-35	18-70	40-140	190	320	3000	15	30	14	38	38	19	38	3.47	3.67	5.6	10.00	1.5	0.15	1	0.11	0.9	
40	19-65	38-130	78-260	380	650	2500	19	40	15	45	45	20	45	4.48	4.48	14.6	20.00	1.8	0.17	1	0.12	0.9	
50	35-110	80-220	160-440	530	900	2000	32	50	20	48	55	28	50	6.59	6.59	29.9	50.00	2.0	0.19	1	0.14	0.9	
60	80-185	160-370	320-740	620	1050	1200	32	60	25	55	60	30	55	10.71	10.71	72.0	114.00	2.1	0.23	1	0.16	0.9	

For Clutch Part No. for ordering refer to page 30.

\*max bore achievable only with keyway according to DIN 6885 Sheet 3

### CZ Series Couplings types P, R & T - Dimensions

Models P & R Size	Dimensions																									
	AA	AB	AC	H	J	K1	L6 MAX	L7 MAX	N	P	P5	P6	P7	P8	S MAX	T	T1	T2	V MIN	W MAX	X2	Z	CH	CH1	CH3	CH4
25	30	-	10.5	7	54.5	12	102	102	63	70	70	55	-	55	42.0	5	2.8	2.8	47	26.5	47.0	1.2	7	7	5	4
30	35	-	11.5	8	69.0	12	120	120	77	85	85	65	-	65	57.0	5	2.8	4.0	56	31.0	54.5	1.5	7	10	6	4
40	45	-	15.5	9	77.0	14	146	146	88	100	100	80	-	80	64.0	5	3.5	4.0	67	40.0	67.0	1.8	8	8/10	6	5
50	50	28	18.0	10	87.5	16	159	159	100	115	115	95	85	95	73.5	6	4.0	4.0	73	29.0	73.0	2	10	10	8	6
60	56	32	21.0	12	106	21	213	213	122	135	135	105	95	105	89.0	7	4.0	4.0	85	45.5	87.0	2.2	10	10	10	8

### Standard Bore sizes available on P, R & T type Clutch clamping hubs, with respective maximum transmittable Torques

Clutch Size	Available Bore sizes in mm (Figures indicate max. transmittable Torque Nm)																				Bolt Torque Nm				
	10	11	12	14	15	16	18	19	20	22	24	25	28	30	32	35	38	40	42	45		48	50	55	60
25	65	70	75	90	95	100	115	120	130	140	150	160													3
30					120	130	150	160	180	190	210	220	240	260											10
40								240	260	290	310	320	360	390											10
40															440	480	520	550							5.9
50															620	680	730	770	810	870	930	970			10
60															620	680	730	770	810	870	930	970	1070	1160	10

### Standard Bore sizes available on P type Coupling clamping hubs, with respective maximum transmittable Torques

Clutch Size	Available Bore sizes in mm (Figures indicate max. transmittable Torque Nm)																		Bolt Torque Nm					
	10	11	14	15	16	19	20	24	25	28	30	32	35	38	40	42	45	48		50	55			
25	34	35	36	38	39	39	41	43	45	46														10.5
30			80	81	81	85	87	91	92	97	99	102	105	109										25
40				92	94	98	99	104	105	109	112	113	118	122	123	126	130							25
50							232	244	246	255	260	266	274	283	294	301	309							69
60								393	405	413	421	434	445	454	462	473	486	494	514					120

### Standard Bore sizes available on R type Coupling clamping hubs, with respective maximum transmittable Torques

Clutch Size	Available Bore sizes in mm (Figures indicate max. transmittable Torque Nm)																		Bolt Torque Nm					
	11	14	15	16	19	20	24	25	28	30	32	35	38	40	42	45	48	50		55				
25	48	67	74	72	90	97	112	120	143															6
30			142	154	188	189	237	250	280	307	310	353	389											6
40						269	337	356	398	436	442	501	533	572	585	644								10
50							399	445	470	506	566	581	630	647	728	836	858							35
60									775	819	955	999	1090	1091	1230	1334	1381	1540						69

Shaft tolerance required for correct operation is h6 up to 40mm dia., h7 for over 40mm.

Tel: +44 121 360 0155

Fax: +44 121 325 1079

Email: sales@crossmorse.com

# Series CN Safeguard Overload Clutches Standard Plain Bore Units

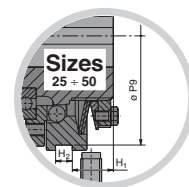

## Standard Zero Backlash Clutches types H&K

These clutches are intended for keyway connection to shafts where pre-machined synchronisation is the preferred design. Type H is used to mount compact drive systems with minimal overhung load, the single deep groove ball bearing providing full radial support for the sprocket, pulley, or gear.

Type K has an extended inner race to support a second Bearing to allow fitment of wider transmission elements, and where high radial loads may be encountered.

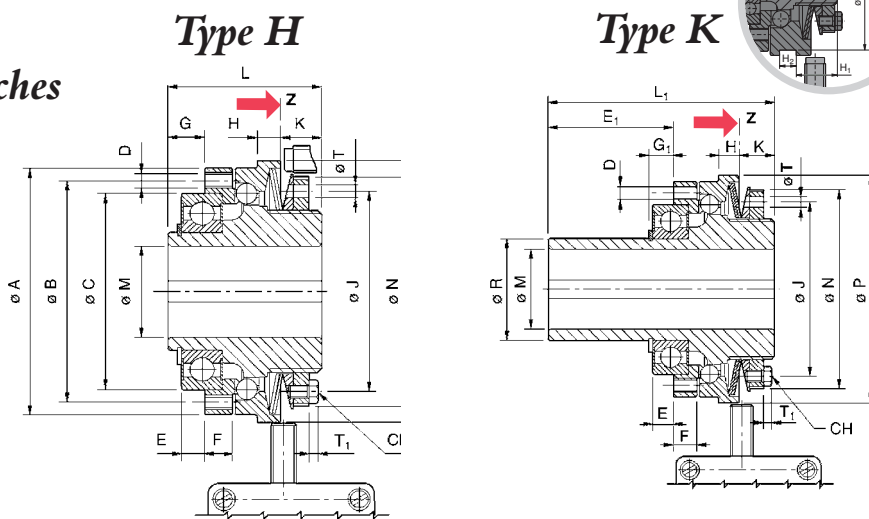

## CN Series types H & K - Technical Capacities

Models H&K Clutch Size	Torque Range according to Spring selection				Max. Speed rpm	Bore Size 'M'		Weight kg		Hub Inertia kgcm <sup>2</sup>		Flange Inertia kg m <sup>2</sup>
	S Nm	M Nm	L Nm	U Nm		min mm	max mm	Type H	Type K	Type H	Type K	
11	0.65 - 3.0	1.3 - 6	2 - 9	2.6 - 12	4000	6	11	0.17	0.19	0.27	0.26	0.08
16	2 - 5	4 - 10	6 - 15	8 - 20	4000	8	16*	0.26	0.30	0.54	0.55	0.2
20	4 - 10	8 - 20	12 - 30	16 - 40	4000	9	20	0.51	0.59	1.8	1.8	0.6
25	4 - 14	8 - 28	12 - 42	16 - 56	4000	12	20	0.89	1.06	4.6	4.8	1.8
30	9 - 35	18 - 70	27 - 105	40 - 140	3000	15	25	1.62	1.77	11.8	12.1	3.9
40	19 - 65	38 - 130	57 - 195	78 - 260	2500	22	35*	2.86	3.28	27.0	27.6	7.7
50	35 - 110	80 - 220	120 - 330	160 - 440	2000	32	45	3.72	4.80	61.5	65.3	17.3

\*For clutch Part No. for ordering refer bottom of page

\*max bore achievable only with keyway according to DIN 6885 Sheet 3

## CN Series types H & K - Dimensions

Clutch Size	A	B	C h <sup>o</sup>	D	E	E'	F	G	G'	H	J	K	L	L'	H'	H <sup>2</sup>	P <sup>o</sup>	N	P	R h <sup>o</sup>	T	T'	Z	CH A/F
11	40	35	30	6XM3	2	20.5	5	4.5	3.0	6	32	7.0	24	40	-	-	-	39.5	45	17	4	2.1	0.8	5.5
16	47	42	37	6XM3	2	25	6	5.0	5.0	8	36.5	9.5	29	49	-	-	-	43	50	25	4	2.1	1.0	5.5
20	60	53	47	6XM4	3	31	7	5.0	5.0	9	36.5	9.5	33	58	-	-	-	43	65	30	4	2.1	1.2	5.5
25	77	69	62	6XM5	4	35	7.5	5.5	5.5	-	54.5	10.2	41	68	14.9	7.5	75	63	80	35	5	2.8	1.2	7.0
30	90	80	68	6XM6	5	40	8	6.5	6.5	-	69	11.0	47	77	17.4	7.5	90	77	95	40	5	4.0	1.5	7.0
40	106	90	80	6XM6	5	48	9	7.0	7.0	-	77	12.6	52	90	20.0	8.0	105	88	110	50	5	4.0	1.8	8.0
50	125	112	100	6XM8	5	60	11	7.5	7.5	-	87.5	14.7	59	109	23.5	9.0	125	100	130	65	6	4.0	2.0	10

For Limit Switch location and operation refer to page 29. Always use limit switch for long service life.

## Clutch Part Numbers for Ordering

To correctly order CN series clutches it is essential to identify the clutch operating mode, size, type, spring ratings (torque range), and for clutches and couplings using Clamping Elements for shaft connection, the shaft diameters.

**Operating Mode:** CN series clutches are available with two operating modes, ratchetting type CNF for applications where synchronisation of input to output is not required, and single position type CNY for full synchronisation.

**Clutch Size:** The clutch size generally indicates the max bore size, and is identified in the tables.

**Clutch Type:** A letter from H to L indicates the clutch design, as shown in the respective drawings.

**Spring Rating:** following a / the letter S, M, L or U indicates the Spring sizes selected, which controls the torque range.

**Bore Sizes:** Except for pilot bored types H and K it is essential that the finish bore sizes of the Clutch/Coupling are provided to enable supply of the unit. Types H, K and M can be supplied with finish bores also if specified.

## Examples

CNF40H/M  
CNY50L/S-40

is a Ratchetting size 40 clutch type 'H' with spring selection M.

is a Synchronous size 50, type L, with spring set S, fitted with 40mm clamping bush.

# Series CN Safeguard Overload Clutches



## Standard Units With Expanding Bush Shaft Connection

Zero Backlash Clutch for keyless shaft connection types J & L. These clutches provide totally backlash free connection of drive gears and sprockets to shafts. A selection of clamping inserts provides a wide range of shaft diameters to be accommodated. Type J can be used to mount compact drive systems, with minimal overhung load, the single deep groove ball bearing providing full radial support.

Type L has extended inner race to support a second bearing to enable fitting of wider transmission elements.

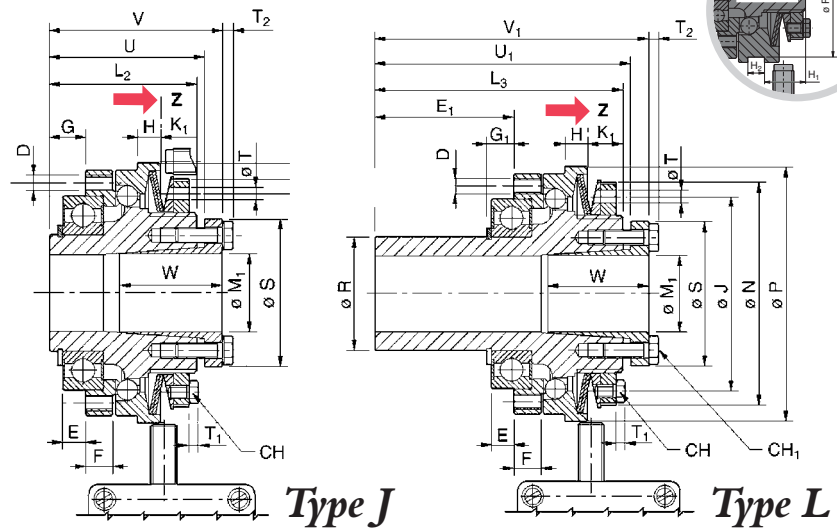

### CN Series types J & L - Technical Capacities

Models J&L Clutch Size	Torque Range according to Spring selection				Max. Speed rpm	Bore Size 'M'		Weight kg		Hub Inertia kgcm <sup>2</sup>		Flange Inertia kgcm <sup>2</sup>
	S Nm	M Nm	L Nm	U Nm		min mm	max mm	Type J	Type L	Type J	Type L	
11	0.65 - 3.0	1.3 - 6	2 - 9	2.6 - 12	4000	6	11	0.18	0.2	0.25	0.28	0.08
16	2 - 5	4 - 10	6 - 15	8 - 20	4000	8	16*	0.28	0.32	0.51	0.58	0.2
20	4 - 10	8 - 20	12 - 30	16 - 40	4000	9	20	0.55	0.63	1.7	1.8	0.6
25	4 - 14	8 - 28	12 - 42	16 - 56	4000	12	20	0.94	1.11	4.6	4.9	1.8
30	9 - 35	18 - 70	27 - 105	40 - 140	3000	15	25	1.63	1.78	11.5	12.5	3.9
40	19 - 65	38 - 130	57 - 195	78 - 260	2500	22	35*	3.03	3.45	26.3	28.4	7.7
50	35 - 110	80 - 220	120 - 330	160 - 440	2000	32	45	3.95	5.03	59.5	67.1	17.3

\*For clutch Part No. for ordering refer bottom of page 34

\*max bore achievable only with keyway according to DIN 6885 Sheet 3

### CN Series types J & L - Dimensions

Clutch Size	A	B	C h <sup>5</sup>	D	E	E'	F	G	G'	K'	L <sup>2</sup>	L <sup>3</sup>	P	R h <sup>6</sup>	H'	H <sup>2</sup>	P <sup>3</sup>	M' min	M' max	S	T <sup>2</sup>	V	V'	W	Z	CH A/F
11	40	35	30	6xM3	2	21	5	4.5	3.0	7	24	40	45	17	-	-	-	6	12	25	2.1	29	45	13	0.8	5.5
16	47	42	37	6xM3	2	25	6	5.0	5.0	9.5	29	49	50	25	-	-	-	8	16	30	2.1	34	54	19	1.0	5.5
20	60	53	47	6xM4	3	31	7	5.0	5.0	9.5	33	58	65	30	-	-	-	9	16	30	2.1	38	63	19	1.2	5.5
25	77	69	62	6xM5	4	35	7.5	5.5	5.5	10	41	68	80	35	14.9	7.5	75	10	20	41	2.8	46	75	26	1.2	7.0
30	90	80	68	6xM6	5	40	8	6.5	6.5	11	47	77	95	40	17.4	7.5	90	15	30	57	4.0	57	87	31	1.5	10
40	106	90	80	6xM6	5	48	9	7.0	7.0	13	52	90	110	50	20.0	8.0	105	19	30	57	4.0	62	100	40	1.8	10
50	125	112	100	6xM8	5	60	11	7.5	7.5	15	59	109	130	65	23.5	9.0	125	32	50	74	4.0	69	119	29	2.0	10

For Limit Switch location and operation refer to page 29. Always use limit switch for long service life.

### Standard Bore sizes available on J & L type clamping hubs, with respective maximum transmittable Torques

Clutch Size	Available Bore sizes in mm (Figures indicate max. transmittable Torque Nm)																				Bolt Torque Nm					
	6	8	9	10	11	12	14	15	16	18	19	20	22	24	25	28	30	32	35	38		40	42	45	48	50
11	13	18	20	23	25	28																				2.2
16		28	30	34	37	41	48	51	54																	1.7
20		28	30	34	37	41	48	51	54																	1.7
25				65	70	75	90	95	100	115	120	130	140	150	160											3
30								95	100	115	160	180	190	210	220	240	260									10
40											240	260	290	310	320	360	390									10
40																		440	480	520	550					5.9
50																		620	680	730	770	810	870	930	970	10

Shaft tolerance required for correct operation is h<sup>6</sup> up to 40mm dia., h<sup>7</sup> for over 40mm.

Tel: +44 121 360 0155

Fax: +44 121 325 1079

Email: sales@crossmorse.com