

Bevel and Mitre Gears



Bevel and Mitre Gears are used to transmit power between shafts intersecting at 90°, on low speed, high torque applications where pitch line velocity does not exceed 5 m/s. All Cross+Morse gears are cut to the Gleason System to provide equal strength between pinion and gear.

Interchangeability

Bevel gears of identical pitch and teeth but from different drive ratio gearsets are not interchangeable. All bevel gears are generated on the pitch cone radius which varies with the ratio of gears within a given diametral pitch.

Installation

All mitre and bevel gears develop end thrust which must be counteracted by bearings of adequate capacity. Accurate and rigid mounting of both gear and pinion provide quiet operation and long life. Bearing spacing and shaft stiffness should be selected to keep shaft deflection below .025mm.

Lubrication

Grease lubrication can be adequate for low speed applications but oil splash lubrication is always preferable. The oil level should cover the face of the lower gear, and sufficient capacity should be available to keep oil temperature below 95°C.

Efficiency

When correctly aligned, a bevel gearset with oil lubrication can operate with transmission efficiency up to 98 per cent.

Power Rating Tables - Standard Metric Mitre Gears

Gear Set Catalogue No.	Gear Speed R.P.M.													
	10	50	100	200	300	400	500	600	800	1000	1200	1500	2000	3000
M1016	.001	.003	.005	.010	.014	.018	.021	.025	.030	.037	.044	.052	.063	.085
M1019	.001	.005	.009	.016	.023	.029	.034	.040	.049	.060	.070	.083	.100	.137
M1022	.002	.008	.015	.026	.037	.046	.055	.066	.079	.097	.114	.135	.164	.222
M1026	.004	.014	.025	.044	.062	.078	.093	.110	.133	.163	.192	.227	.275	.374
M1030	.006	.021	.038	.069	.096	.121	.145	.171	.206	.253	.298	.352	.427	.580
M1516	.003	.010	.017	.031	.044	.055	.066	.078	.094	.115	.136	.161	.195	.264
M1519	.005	.017	.030	.055	.077	.097	.115	.136	.164	.201	.237	.280	.340	.462
M1522	.007	.027	.048	.085	.119	.150	.179	.211	.255	.313	.368	.435	.528	.717
M1526	.012	.043	.078	.139	.195	.215	.293	.346	.417	.512	.603	.712	.863	1.172
M1530	.019	.069	.123	.220	.308	.387	.462	.545	.657	.806	.950	1.122	1.361	1.848
M2016	.006	.022	.039	.070	.099	.124	.148	.175	.210	.258	.304	.359	.436	.592
M2019	.010	.038	.068	.121	.169	.212	.253	.299	.360	.442	.521	.616	.747	1.014
M2022	.016	.060	.107	.191	.267	.336	.401	.474	.570	.700	.825	.974	1.182	1.605
M2026	.028	.101	.180	.322	.451	.567	.676	.799	.962	1.181	1.392	1.643	1.993	2.706
M2030	.042	.152	.272	.485	.680	.854	1.019	1.204	1.450	1.780	2.097	2.475	3.003	4.077
M2516	.001	.004	.007	.013	.018	.023	.027	.033	.039	.048	.057	.067	.081	1.10
M2519	.002	.007	.012	.022	.031	.039	.047	.055	.066	.081	.096	1.14	1.38	1.87
M2522	.003	.011	.019	.035	.049	.061	.073	.086	1.04	1.28	1.50	1.78	2.15	2.93
M2526	.005	.019	.033	.060	.084	1.05	1.26	1.48	1.79	2.20	2.59	3.06	3.71	
M2530	.007	.028	.050	.089	1.25	1.58	1.88	2.23	2.68	3.29	3.88	4.58	5.55	
M3016	.002	.007	.012	.022	.030	.038	.046	.054	.065	.080	.095	1.12	1.35	1.84
M3019	.003	.011	.021	.037	.051	.065	.077	.091	1.10	1.35	1.59	1.88	2.28	3.10
M3022	.005	.018	.033	.059	.083	1.05	1.25	1.47	1.77	2.18	2.57	3.03	3.68	
M3026	.008	.030	.054	.097	1.36	1.71	2.04	2.41	2.90	3.56	4.20	4.96	6.01	
M3030	.013	.046	.083	1.48	2.08	2.62	3.12	3.69	4.44	5.45	6.42	7.58	9.20	
M3516	.003	.010	.019	.034	.047	.059	.071	.084	1.01	1.24	1.46	1.72	2.09	2.84
M3519	.005	.017	.031	.056	.079	.099	1.18	1.40	1.69	2.07	2.44	2.88	3.49	
M3522	.007	.028	.050	.090	1.26	1.58	1.89	2.23	2.69	3.30	3.89	4.59	5.57	
M3526	.013	.047	.084	1.50	2.10	2.64	3.15	3.73	4.49	5.51	6.49	7.66	9.30	
M3530	.020	.073	1.31	2.34	3.27	4.11	4.91	5.80	6.98	8.57	10.10	11.92		
M4016	.004	.015	.026	.047	.066	.083	1.00	1.18	1.42	1.74	2.05	2.42	2.94	4.00
M4019	.007	.026	.047	.084	1.18	1.48	1.76	2.09	2.51	3.08	3.63	4.29	5.20	
M4022	.011	.041	.074	1.33	1.86	2.34	2.79	3.29	3.97	4.87	5.74	6.77	8.22	
M4026	.020	.072	1.28	2.29	3.20	4.03	4.80	5.67	6.83	8.39	9.89	11.67		
M4030	.029	1.06	1.89	3.38	4.73	5.95	7.10	8.38	10.10	12.40	14.60	17.24		
M4516	.006	.021	.037	.067	.094	1.18	1.41	1.67	2.01	2.47	2.91	3.44	4.17	
M4519	.010	.036	.065	1.16	1.63	2.04	2.44	2.88	3.47	4.26	5.02	5.93	7.19	
M4522	.016	.057	1.02	1.83	2.56	3.21	3.84	4.53	5.46	6.70	7.90	9.32		
M4526	.026	.093	1.67	2.99	4.19	5.26	6.28	7.42	8.93	10.97	12.92	15.25		
M4530	.040	1.46	2.62	4.67	6.54	8.22	9.81	11.59	13.96	17.14	20.19			
M5016	.007	.027	.048	.087	1.22	1.53	1.83	2.16	2.60	3.19	3.76	4.44	5.39	
M5019	.013	.048	.087	1.55	2.17	2.73	3.26	3.85	4.63	5.69	6.70	7.92	9.11	
M5022	.021	.076	1.36	2.43	3.40	4.27	5.10	6.02	7.25	8.90	10.49	12.38		
M5026	.035	1.29	2.30	4.12	5.76	7.24	8.64	10.21	12.30	15.09	17.78			
M5030	.054	1.96	3.50	6.25	8.75	11.00	13.13	15.51	18.67	22.93	27.01			

Selections in tinted area have pitch line velocity over 5 m/s. For these selections it is recommended teeth are induction hardened.

Design and Selection

The power steel bevel gears can transmit under ideal lubrication conditions is normally limited by wear life. The following tables give design power in kW for a normal operating life of 10,000 hours for stock gears. For increased life gears can be induction hardened.

For correct selection of a Bevel Gearset first assemble application data, including Power, shaft speeds and drive ratio required.

- From details of Driver and Driven equipment select correct Service Factor from table below.
- Calculate Design Power kW
Design Power = Actual Power × Service factor.
- If Drive ratio not available determine from
Ratio = $\frac{R.P.M. \text{ High Speed Shaft}}{R.P.M. \text{ Low Speed Shaft}}$
- From table for Drive Ratio (i.e. 1:1 Mitre Gear, 1.5:1 to 4:1 Bevel Gears), select smallest gearset where Power equals or exceeds Design power at Pinion R.P.M. For variable speed drives check selection at max. shaft speed, torque and power.

For useful formulae on Bevel Gears design refer to appendix pages.

Design Factors

Power Source	Character of Load of Driven Equipment		
	Uniform	Moderate Shock	Heavy Shock
Uniform	1.00	1.25	1.75
Light Impulse	1.25	1.50	2.00
Heavy Impulse	1.50	1.75	2.25

For speed increase drives add 0.1 to above factors.

Bevel and Mitre Gears



Power Rating Tables - Standard Metric Bevel Gears

Gear Set Catalogue No.	Gear Speed R.P.M.													
	10	50	100	200	300	400	500	600	800	1000	1200	1500	2000	3000
1.5:1 Ratio - Standard Metric Bevel Gears														
M101624	.001	.004	.007	.013	.019	.024	.028	.033	.040	.050	.058	.069	.084	.114
M151624	.004	.014	.026	.047	.065	.083	.098	.116	.140	.172	.203	.239	.290	.394
M201624	.009	.032	.057	.102	.143	.179	.214	.253	.305	.374	.441	.520	.631	.857
M251624	.017	.061	.108	.194	.272	.342	.407	.481	.579	.711	.838	.989	1.200	1.630
M301624	.027	.098	.175	.313	.438	.550	.657	.776	.934	1.147	1.351	1.595	1.935	2.627
M351624	.043	.155	.277	.495	.694	.872	1.040	1.229	1.480	1.817	2.140	2.527	3.065	4.162
M401624	.058	.211	.377	.674	.944	1.186	1.415	1.672	2.013	2.472	2.912	3.438	4.171	5.663
M451624	.080	.292	.521	.931	1.304	1.639	1.956	2.310	2.782	3.415	4.023	4.750	5.762	
M501624	.113	.408	.729	1.302	1.823	2.292	2.734	3.229	3.889	4.775	5.625	6.641	8.056	
2.0:1 Ratio - Standard Metric Bevel Gears														
M101530	.001	.004	.008	.015	.021	.026	.031	.036	.044	.054	.064	.075	.091	.124
M151530	.004	.016	.028	.050	.071	.089	.106	.125	.151	.185	.218	.257	.312	.424
M201530	.009	.035	.062	.110	.155	.195	.232	.274	.330	.406	.478	.564	.685	.930
M251530	.018	.066	.118	.211	.295	.371	.442	.532	.629	.773	.910	1.075	1.304	1.771
M301530	.029	.107	.191	.342	.479	.602	.718	.848	1.022	1.254	1.478	1.745	2.116	2.874
M351530	.046	.168	.300	.535	.750	.942	1.124	1.328	1.599	1.963	2.313	2.713	3.313	4.498
M401530	.066	.239	.427	.763	1.069	1.344	1.603	1.893	2.280	2.800	3.298	3.894	4.723	6.413
M451530	.093	.336	.601	1.074	1.504	1.890	2.255	2.664	3.208	3.939	4.640	5.478	6.645	
M501530	.127	.460	.822	1.468	2.056	2.585	3.084	3.642	4.386	5.385	6.344	7.490	9.085	
3.0:1 Ratio - Standard Metric Bevel Gears														
M101545	.002	.007	.013	.023	.033	.040	.048	.057	.069	.084	.098	.117	.142	.193
M151545	.006	.022	.040	.071	.099	.125	.149	.176	.212	.260	.307	.362	.440	.597
M201545	.013	.049	.089	.158	.222	.279	.331	.393	.473	.582	.685	.809	.981	1.332
M251545	.026	.094	.168	.300	.421	.529	.631	.746	.898	1.103	1.299	1.534	1.860	2.526
M301545	.043	.154	.276	.494	.691	.869	1.037	1.224	1.474	1.810	2.132	2.517	3.054	4.147
M351545	.064	.232	.415	.741	1.038	1.305	1.557	1.839	2.214	2.718	3.203	3.781	4.587	6.227
M401545	.095	.342	.612	1.093	1.530	1.923	2.294	2.709	3.263	4.006	4.720	5.572	6.759	9.178
M451545	.125	.452	.809	1.445	2.023	2.543	3.034	3.583	4.316	5.298	6.242	7.370	8.940	
M501545	.172	.624	1.115	1.992	2.789	3.506	4.184	4.940	5.950	7.305	8.605	10.160	12.325	
4.0:1 Ratio - Standard Metric Bevel Gears														
M101560	.002	.009	.017	.031	.043	.055	.065	.077	.092	.114	.134	.158	.192	.261
M151560	.007	.026	.046	.083	.116	.146	.175	.206	.248	.305	.359	.424	.515	.698
M201560	.017	.062	.110	.197	.276	.347	.414	.489	.589	.723	.852	1.005	1.220	1.656
M251560	.031	.111	.199	.356	.498	.626	.748	.883	1.063	1.305	1.538	1.816	2.203	2.991
M301560	.051	.187	.334	.597	.836	1.050	1.254	1.480	1.783	2.189	2.579	3.045	3.693	5.015
M351560	.078	.282	.504	.900	1.260	1.584	1.890	2.232	2.688	3.300	3.888	4.590	5.569	7.561
M401560	.114	.412	.736	1.315	1.842	2.315	2.763	3.263	3.929	4.824	5.684	6.709	8.139	11.050
M451560	.152	.553	.988	1.764	2.470	3.105	3.705	4.375	5.270	6.470	7.620	9.000	10.915	
M501560	.199	.719	1.285	2.295	3.210	4.040	4.820	5.690	6.855	8.415	9.920	11.700	14.200	

Power Rating Tables - Imperial Series D.P. Stock Bevel and Mitre Gears

Gear Set Catalogue No.	Pinion Speed R.P.M.													
	10	50	100	200	300	400	500	600	800	1000	1200	1500	2000	3000
Mitre Gears - D.P. Standard														
1618	.005	.020	.035	.064	.089	.112	.134	.158	.190	.233	.275	.325	.394	.535
1218	.012	.045	.081	.145	.203	.255	.304	.359	.433	.531	.626	.739	.897	1.218
1224	.029	.107	.191	.341	.478	.601	.717	.847	1.020	1.252	1.475	1.742	2.113	2.870
1024	.052	.188	.336	.600	.840	1.056	1.261	1.489	1.793	2.201	2.593	3.062	3.714	5.043
824	.098	.353	.632	1.128	1.580	1.986	2.370	2.800	3.370	4.135	4.875	5.750	6.980	
624	.216	.780	1.395	2.490	3.490	4.385	5.230	6.180	7.440	9.130	10.760	12.710		
524	.350	1.265	2.260	4.040	5.650	7.110	8.480	10.20	12.060	14.810	17.450	20.600		
2:1 Ratio - Standard D.P. Gears														
161530	.005	.019	.034	.060	.084	.106	.126	.149	.180	.221	.260	.307	.372	.506
121530	.013	.046	.083	.148	.207	.260	.311	.367	.442	.542	.639	.755	.916	1.294
101530	.022	.079	.140	.251	.352	.442	.527	.623	.750	.921	1.085	1.281	1.554	2.110
81530	.041	.149	.266	.476	.666	.837	.999	1.180	1.421	1.745	2.056	2.427	2.944	4.000
61530	.094	.338	.605	1.080	1.511	1.900	2.267	2.677	3.225	3.959	4.664	5.506	6.680	9.070
3:1 Ratio - Standard D.P. Gears														
161236	.004	.015	.026	.047	.066	.083	.099	.117	.141	.173	.204	.241	.292	.397
121236	.008	.030	.055	.098	.137	.172	.206	.243	.293	.359	.423	.500	.606	.823
101236	.015	.056	.100	.180	.252	.317	.378	.446	.537	.659	.777	.917	1.113	1.511
81236	.028	.103	.184	.329	.461	.580	.692	.817	.984	1.208	1.423	1.680	2.038	2.767
61236	.064	.231	.421	.737	1.031	1.296	1.547	1.827	2.200	2.701	3.182	3.757	4.558	6.188

Selections in tinted area have pitch line velocity over 5 m/s. For these selections it is recommended teeth are induction hardened.

Tel +44 121 360 0155

Fax +44 121 325 1079

Email sales@crossmorse.com

Standard D.P. Mitre and Bevel Gears

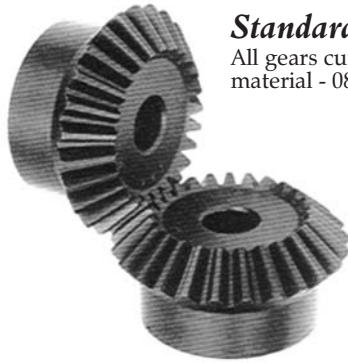

Standard D.P. Mitre Gears
All gears cut 20° pressure angle
material - 080M40

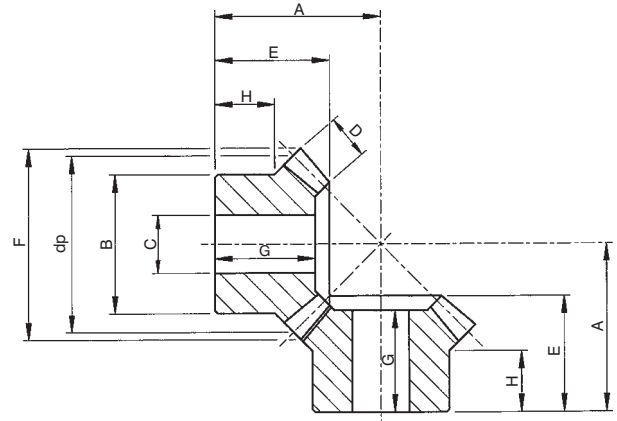

Imperial Series Mitre Gears 16 D.P. to 5 D.P.

Catalogue No.	D.P.	No. of Teeth	Pitch Dia. dp	A	B	C		D	E	F	G	H	Approx Wt. per Gear kg
						Min	Max						
1618	16	18	28.57	26.19	22.2	7.94	12	7.9	18.0	30.7	16.5	8.7	0.05
1218	12	18	38.10	34.92	31.7	9.52	16	11.1	24.4	41.1	22.1	12.7	0.12
1224	12	24	50.80	47.62	41.3	12.70	23	12.7	32.0	53.8	29.7	17.5	0.30
1024	10	24	60.96	53.97	50.8	15.87	27	17.5	36.8	64.5	34.3	18.4	0.50
824	8	24	76.20	69.85	50.8	15.87	32	22.2	48.5	80.8	45.5	19.1	0.86
624	6	24	101.60	88.90	66.7	25.40	44	28.6	59.9	107.7	55.1	20.6	1.84
524	5	24	121.92	101.60	76.2	31.75	51	31.7	65.0	129.0	58.9	17.8	2.88

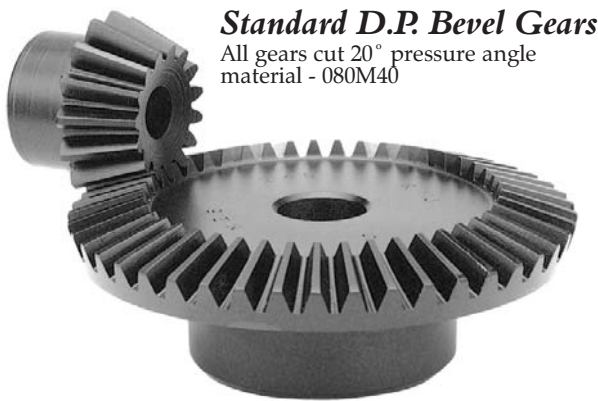

Standard D.P. Bevel Gears
All gears cut 20° pressure angle
material - 080M40

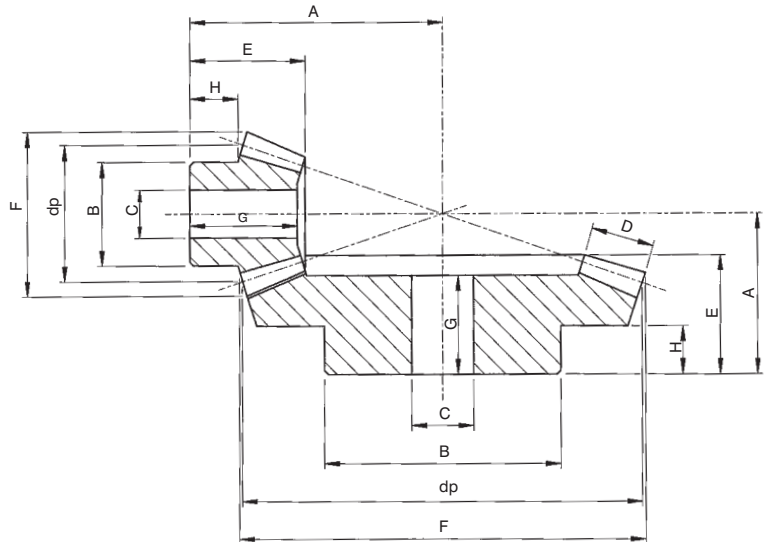

Imperial Series Bevel Gears 16 D.P. to 6 D.P.

Catalogue No.	D.P.	No. of Teeth	Pitch Dia. dp	A	B	C		D	E	F	G	H	Approx Wt. per Gear kg
						Min	Max						
Bevel Gear Sets 2:1 Ratio													
161530	16	15 30	23.80 47.62	34.92 25.40	17.5 34.9	7.94 9.52	11 24	7.9 7.9	18.8 17.5	27.7 48.5	17.5 15.5	9.3 7.2	0.04 0.14
121530	12	15 30	31.75 63.50	43.66 33.33	25.4 42.9	9.52 12.70	15 28	12.7 12.7	23.9 23.9	36.8 64.8	22.1 21.1	10.3 9.3	0.08 0.31
101530	10	15 30	38.10 76.20	50.80 38.10	28.6 44.5	9.52 12.70	17 29	15.8 15.8	27.7 26.9	44.2 77.7	25.1 23.4	10.3 10.3	0.14 0.48
81530	8	15 30	47.62 95.25	63.50 57.15	34.9 60.3	12.70 15.87	22 40	20.6 20.6	35.3 43.4	55.4 97.0	32.8 39.4	12.3 17.6	0.27 1.26
61530	6	15 30	63.50 127.00	85.72 73.12	44.5 79.4	19.05 19.05	28 53	28.6 28.6	49.0 55.1	73.7 129.5	45.5 49.8	17.8 21.9	0.60 2.94
Bevel Gear Sets 3:1 Ratio													
161236	16	12 36	19.05 57.15	38.10 25.40	14.3 38.1	7.94 12.70	9 26	9.5 9.5	19.1 19.6	23.4 57.7	19.1 16.2	9.8 6.3	0.02 0.22
121236	12	12 36	25.40 76.20	50.80 31.75	19.1 50.8	9.52 12.70	11 34	11.1 11.1	23.9 23.4	31.0 77.0	23.9 19.3	11.6 10.3	0.05 0.44
101236	10	12 36	30.48 91.44	57.15 44.45	25.4 57.2	9.52 14.29	14 38	15.8 15.8	27.2 35.1	37.3 92.5	27.2 30.2	10.6 12.7	0.05 1.02
81236	8	12 36	38.10 114.30	71.44 44.45	31.7 76.2	12.70 15.87	18 50	19.1 19.1	33.3 32.5	46.5 115.6	33.3 26.2	13.2 12.7	0.19 1.44
61236	6	12 36	50.80 152.40	101.60 63.50	41.3 95.3	19.05 25.40	24 63	25.4 25.4	50.8 47.7	62.2 153.9	50.8 40.4	23.8 19.1	0.45 3.64

All Gears Stocked with Standard Plain Bore. Rebore, Keyway, Setscrew and Induction Hardening Services available.
Bevel and Mitre Gears with other D.P. and Module can be supplied to order up to 375mm diameter.

Standard Metric Mitre Gears



Gear Type 'A' *

Gear Type 'B'

Standard Metric Mitre Gears
Manufactured in medium carbon steels for high strength and durability.
All gears cut 20 degree pressure angle.

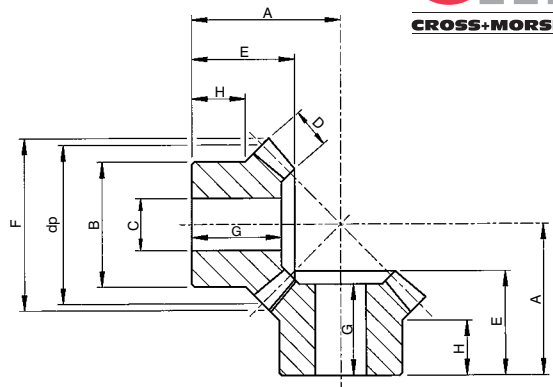

Cross+Morse standard stock metric mitre gears complement the existing range of diametral pitch gears to provide the designer a wider range of selection. The mitre gear sets are available in 7 tooth sizes in 9 pitches from 1.0 Mod to 5.0 Mod, providing the correct solution for right angle drives in applications from light instrumentation and office equipment to heavy manufacturing machinery.

All gears are manufactured in medium carbon steels for high strength and durability, and can be optionally induction/flame hardened for more arduous applications. The gears are cut to the Gleason System with 20 degree pressure angle, and supplied only in pairs to ensure correct matching.

For long life and efficient operation it is essential that mitre gears are correctly mounted on rigidly supported shafts with bearings able to support the axial and radial loads imposed. The shafts should be at a true right angle within the following tolerances:-

Shaft Axis to intersect within $\pm 0.025\text{mm}$. Shafts to be at right angles within $\pm 5'$ angle. The mounting distance (Dimension 'A') to be true within $+0.0/-0.05\text{mm}$

Cat. No.	Pitch Module	No. Teeth	Type	dp	A	B	Bore C		D	E	F	G	H	Approx Weight per Gear Kg
							min	max						
M1016	1	16	B	16.0	16.00	13.3	4	7.5	4.0	11.2	17.4	11.2	6.5	0.013
M1019		19	B	19.0	18.00	15.3	4	9.0	4.0	11.8	20.4	11.8	6.5	0.015
M1022		22	B	22.0	20.00	16.3	5	10.0	4.7	12.8	23.4	12.8	6.5	0.022
M1026		26	B	26.0	22.00	20.3	5	13.0	5.5	13.3	27.4	13.3	7.0	0.033
M1030		30	B	30.0	26.00	20.3	5	13.0	6.4	16.0	31.4	16.0	8.0	0.040
M1516	1.5	16	B	24.0	26.00	20.3	8	10.0	6.0	18.9	26.1	18.9	12.0	0.028
M1519		19	B	28.5	30.00	20.3	8	12.5	6.0	21.3	30.6	21.3	12.0	0.050
M1520		20	A	30.0	27.40	22.0	8	14.0	10.0	20.0	32.1	18.0	8.5	0.061
M1522		22	B	33.0	33.00	25.3	8	16.0	7.5	22.5	35.1	22.5	12.0	0.081
M1525		25	A	37.5	34.09	28.0	10	18.0	10.0	23.0	39.6	21.0	12.0	0.111
M1526		26	B	39.0	36.00	28.3	8	19.0	8.5	23.2	41.1	23.2	12.0	0.117
M1530		30	B	45.0	42.00	30.3	12	20.0	10.0	27.2	47.1	27.2	12.0	0.167
M2016	2	16	B	32.0	33.00	25.3	8	14.0	8.0	23.5	34.8	23.5	14.0	0.070
M2019		19	B	38.0	36.00	25.3	8	16.0	9.0	24.2	40.8	24.2	12.0	0.105
M2020		20	A	40.0	35.78	32.0	10	18.0	12.0	25.0	42.8	22.0	12.0	0.158
M2022		22	B	44.0	42.00	30.3	12	20.0	10.0	27.9	46.8	27.9	14.0	0.158
M2025		25	A	50.0	42.28	40.0	12	24.0	14.0	28.0	52.8	25.0	12.3	0.280
M2026		26	B	52.0	48.00	35.3	12	24.0	12.0	31.4	54.8	31.4	14.0	0.261
M2030		30	B	60.0	54.00	40.3	14	27.0	13.0	34.1	62.8	34.1	17.0	0.385
M2516		2.5	16	B	40.0	40.00	30.3	12	18.0	10.0	28.1	43.5	28.1	15.0
M2519	19		B	47.5	42.00	35.3	12	23.0	11.0	27.1	51.0	27.1	13.0	0.200
M2520	20		A	50.0	45.93	40.0	12	26.0	12.0	30.5	53.5	27.0	16.0	0.300
M2522	22		B	55.0	48.00	45.3	16	28.0	12.0	30.1	58.5	30.1	16.0	0.328
M2525	25		A	62.5	52.98	50.0	15	34.0	15.0	33.5	66.0	30.0	16.0	0.520
M2526	26		B	65.0	54.00	45.3	16	30.0	15.0	33.2	68.5	33.2	16.0	0.490
M2530	30		B	75.0	64.00	50.3	16	34.0	16.0	39.0	78.5	39.0	20.0	0.700
M3016	3	16	B	48.0	45.00	40.3	12	21.0	12.0	31.7	52.2	31.7	18.0	0.280
M3019		19	B	57.0	54.00	40.3	14	27.0	13.0	36.0	61.2	36.0	17.0	0.370
M3020		20	A	60.0	51.00	45.0	15	30.0	18.0	35.0	64.2	31.0	13.6	0.450
M3022		22	B	66.0	58.00	50.3	16	34.0	15.0	36.9	70.2	36.9	17.0	0.540
M3025		25	A	75.0	60.00	55.0	15	37.0	20.0	38.0	79.2	34.0	16.0	0.770
M3026		26	B	78.0	64.00	50.3	16	34.0	17.0	38.4	82.2	38.4	18.0	0.750
M3030		30	B	90.0	74.00	60.3	20	40.0	19.0	43.8	94.2	43.8	22.0	0.950
M3516	3.5	16	B	56.0	53.00	45.3	16	24.0	14.0	36.4	61.0	36.4	20.0	0.450
M3519		19	B	66.5	58.80	50.3	18	34.0	15.0	37.8	71.5	37.8	19.0	0.650
M3520		20	A	70.0	58.63	55.0	15	37.0	22.0	40.5	75.0	36.0	17.0	0.790
M3522		22	B	77.0	64.00	55.3	20	37.0	17.0	39.1	82.0	39.1	18.0	0.720
M3525		25	A	87.5	67.47	65.0	20	44.0	26.0	43.5	92.5	39.0	18.0	1.200
M3526		26	B	91.0	73.05	62.3	20	41.0	20.0	43.4	96.0	43.4	20.0	1.290
M3530		30	B	105.0	82.00	70.3	20	46.0	23.0	47.1	110.0	47.1	22.0	1.800
M4016	4	16	B	64.0	64.00	50.3	16	31.0	15.0	44.3	69.7	44.3	25.0	0.680
M4019		19	B	76.0	68.00	55.3	20	36.0	18.0	44.4	81.7	44.4	22.0	0.900
M4020		20	A	80.0	63.74	60.0	18	40.0	25.0	43.0	85.7	38.0	18.0	1.000
M4022		22	B	88.0	74.00	60.3	20	40.0	20.0	45.9	93.7	45.9	22.0	1.050
M4025		25	A	100.0	73.50	70.0	20	46.0	28.0	45.0	105.7	40.0	18.0	1.530
M4026		26	B	104.0	82.00	70.3	20	46.0	25.0	48.0	109.7	48.0	22.0	1.900
M4030		30	B	120.0	94.00	80.3	20	54.0	26.0	54.2	125.7	54.2	25.0	2.450
M4516	4.5	16	B	72.0	68.00	55.3	20	34.0	17.5	46.3	78.4	46.3	25.0	0.750
M4519		19	B	85.5	75.57	62.3	20	41.0	20.0	49.0	91.9	49.0	25.0	1.290
M4520		20	A	90.0	71.41	65.0	20	44.0	28.0	48.0	96.4	42.0	18.0	1.370
M4522		22	B	99.0	82.00	70.3	20	46.0	22.0	50.1	105.4	50.1	25.0	1.550
M4525		25	A	112.5	81.76	75.0	20	50.0	32.0	50.0	118.9	44.0	18.0	2.070
M4526		26	B	117.0	93.30	75.3	20	50.0	25.0	54.7	123.4	54.7	26.0	2.790
M4530		30	B	135.0	105.00	80.3	20	54.0	29.0	60.0	141.4	60.0	28.0	3.100
M5016	5	16	B	80.0	74.00	60.3	20	40.0	18.0	48.9	87.1	48.9	25.0	0.920
M5019		19	B	95.0	82.00	60.3	20	40.0	22.0	52.2	102.1	52.2	25.0	1.500
M5020		20	A	100.0	77.36	70.0	20	46.0	30.0	50.5	107.1	44.0	18.5	1.730
M5022		22	B	110.0	94.00	80.3	20	54.0	24.0	58.2	117.1	58.2	30.0	2.390
M5025		25	A	125.0	89.86	90.0	20	60.0	34.0	53.5	132.1	47.0	18.0	3.080
M5026		26	B	130.0	105.00	80.3	20	54.0	29.0	62.7	137.1	62.7	30.0	3.140
M5030		30	B	150.0	119.00	80.3	20	54.0	32.0	68.9	157.1	68.9	35.0	4.200

All gears stocked with standard plain bore. Rebore, keyway, setscrew and induction hardening services available.
Bevel and mitre gears with other D.P. and module can be supplied to order up to 375mm diameter. All dimensions in mm.
*Type A where 'G' less than 'E'

Tel +44 121 360 0155

Fax +44 121 325 1079

Email sales@crossmorse.com

Standard Metric Series Bevel Gears



Cross+Morse standard stock bevel gears complement the existing range of diametral pitch gears to provide the designer a wider range of selection. Available in 4 standard ratios with 9 different pitches ranging from 1.0 Mod to 5.0 Mod, these bevels provide the ideal solution for many right angle drive applications from light instrumentation to rugged manufacturing plant and agricultural equipment. All gears are manufactured in medium carbon steels for high strength and durability, and can be optionally induction/flame hardened for more arduous applications. The gears are all gear cut to the Gleason System with 20 degree pressure angle, and supplied only in complete sets to ensure correct matching.

For long life and efficient operation it is essential that bevel gears are correctly mounted on rigidly supported shafts with bearings able to support the axial and radial loads imposed. The shafts should be at a true right angle within the following tolerances:-

Shaft Axis to intersect within $\pm 0.025\text{mm}$

Shafts to be at right angles within $\pm 5'$ angle

The mounting distance (Dimension 'A') to be true within $+0.0/-0.05\text{mm}$

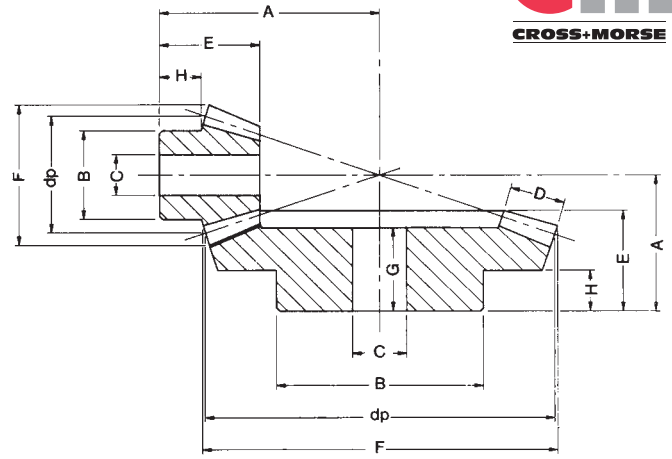

Metric Series Bevel Gears 1.0 Mod to 5.0 Mod

Catalogue No.	Pitch Module	No. Teeth	Pitch Dia. dp	A	B	Bore C		D	E	F	G	H	Approx Wt. kg
						min	max						
Bevel Gear Sets 1.5 : 1 Ratio													
M101624	1	16 24	16.0 24.0	20 20	13.3 20.3	4 5	8 12	4.3 4.3	12.0 14.8	18.1 24.8	12.0 13.3	7.0 9.3	.012 .035
M151624	1.5	16 24	24.0 36.0	31 32	20.3 28.3	8 8	10 13	8 8	20.3 24.9	27.1 37.2	20.3 22.7	11.8 16.0	.040 .115
M201624	2	16 24	32.0 48.0	40 37	25.3 32.3	8 8	15 21	10 10	25.2 27.2	36.2 49.7	25.2 24.7	13.8 16.0	.080 .255
M251624	2.5	16 24	40.0 60.0	49 46	32.3 45.3	12 16	18 29	13 13	30.8 34.0	45.2 62.1	30.8 30.8	16.4 20.0	.17 .40
M301624	3	16 24	48.0 72.0	55 51	40.3 55.3	12 16	23 36	14.5 14.5	32.4 36.2	54.3 74.5	32.4 32.0	16.4 20.0	.30 .65
M351624	3.5	16 24	56.0 84.0	66 61	45.3 55.3	16 20	26 36	18 18	40.4 44.2	63.3 86.9	40.4 40.0	20.4 25.0	.57 .90
M401624	4	16 24	64.0 96.0	78 66	50.3 60.3	16 20	32 40	18 18	46.8 45.5	72.4 99.3	46.8 40.0	25.4 25.0	.68 1.20
M451624	4.5	16 24	72.0 108.0	83 81	60.3 80.3	20 20	38 54	20 20	47.6 57.8	81.4 111.7	47.6 51.3	25.1 35.0	.93 2.20
M501624	5	16 24	80.0 120.0	92 86	60.3 80.3	20 20	40 54	24 24	54.1 61.1	90.5 124.1	54.1 54.5	25.4 35.0	1.06 2.40
Bevel Gear Sets 2.0 : 1 Ratio													
M101530	1	15 30	15.0 30.0	22 20	13.3 20.3	4 5	8 13	5 5	11.9 15.1	17.4 30.6	11.9 13.7	6.5 9.0	.010 .040
M151530	1.5	15 30	22.5 45.0	35 32	19.3 32.3	8 8	10 21	9 9	21.1 25.2	26.1 45.9	21.1 23.0	11.9 16.0	.040 .170
M151632	1.5	16 32	24.0 48.0	35.83 27.45	21.0 32.0	10 12	11 21	8 8	19.5 20.0	26.7 49.3	18.0 17.0	11.3 10.0	.04 .12
M201530	2	15 30	30.0 60.0	45 39	25.3 40.3	8 14	13 27	11.5 11.5	26.0 29.8	34.8 61.2	26.0 26.8	14.1 18.0	.090 .320
M201632	2	16 32	32.0 64.0	45.41 35.21	26.0 40.0	10 12	15 27	10 10	23 25.0	35.6 65.8	21.0 21.0	11.9 10.0	.08 .26
M251530	2.5	15 30	37.5 75.0	55 45	32.3 45.3	12 16	17 30	15 15	31.8 33.7	43.5 76.5	31.8 30.0	16.2 20.0	.170 .500
M251632	2.5	16 30	40.0 75.0	55.88 45	34.0 40.3	12 14	18 27	12 11.5	27.5 29.8	44.5 61.2	25.0 26.8	14.4 18.0	.170 .320
M301530	3	15 30	45.0 90.0	66 56	40.3 55.3	12 16	22 36	17 17	37.3 42.1	52.2 91.8	37.3 38.0	19.9 25.0	.315 .960
M301632	3	16 32	48.0 96.0	61.64 45.31	40.0 60.0	15 15	24 40	15 15	28.0 30.0	53.4 98.7	25.0 24.0	11.6 10.0	.23 .72
M351530	3.5	15 30	52.5 105.0	79 61	45.3 60.3	16 20	25 40	20.5 20.5	46.1 45.0	60.9 107.1	46.1 40.0	24.7 25.0	.49 1.35
M351632	3.5	15 30	52.5 105.0	79 61	45.3 60.3	16 20	25 40	20.5 20.5	46.1 45.0	60.9 107.1	46.1 40.0	24.7 25.0	.49 1.35
M401530	4	15 30	60.0 120.0	87 76	50.3 80.3	20 20	30 54	22.5 22.5	48.6 57.3	69.6 122.3	48.6 51.9	24.6 35.0	.63 2.45
M401632	4	16 32	64.0 128.0	80.81 52.42	50.0 80.0	15 20	32 54	20 20	36.0 32.0	71.2 131.6	32.0 24.0	13.4 10.0	.52 1.32
M451530	4.5	15 30	67.5 135.0	94 81	60.3 80.3	20 20	34 54	26 26	51.4 60.3	78.3 137.6	51.4 54.3	24.7 35.0	1.20 3.18
M451632	4.5	16 32	72.0 144.0	90.5 59.21	60.0 90.0	20 20	36 60	22 22	39.5 36.0	80.1 148.0	35.0 27.0	15.4 10.0	.76 1.94
M501530	5	15 30	75.0 150.0	104 85	60.3 80.3	20 20	37 54	30 30	57.6 62.5	87.0 152.9	57.6 56.0	25.3 35.0	1.38 3.87
M501632	5	16 32	80.0 160.0	106.06 63.52	60.0 100.0	20 20	40 65	25 25	50.0 38.0	88.9 164.5	45.0 28.0	21.1 10.0	1.04 2.53

All dimensions in mm.

All gears stocked with standard plain bore. Rebore, keyway, setscrew and induction hardening services available.

Bevel and mitre gears with other D.P. and module can be supplied to order up to 375mm diameter.

Standard Metric Bevel Gears

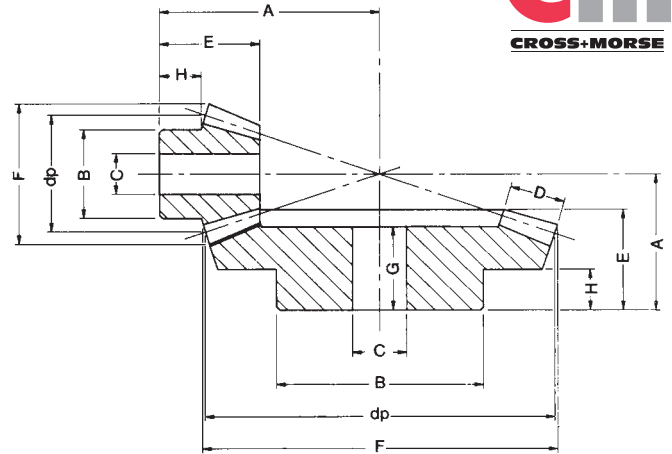

Metric Series Bevel Gears 1.0 Mod to 5.0 Mod

Catalogue No.	Pitch Module	No. Teeth	Pitch Dia. dp	A	B	Bore C		D	E	F	G	H	Approx Wt. kg
						min	max						
Bevel Gear Sets 3 : 1 Ratio													
M101545	1	15	15.0	32.00	13.3	4	8	7.1	16.6	17.7	16.6	9.2	0.02
		45	45.0	22.00	25.3	8	16	7.1	17.1	45.3	15.2	10.0	0.09
M151545	1.5	15	22.5	46.00	19.3	8	10	10.5	22.6	26.5	22.6	11.7	0.05
		45	67.5	37.00	45.3	14	30	10.5	29.6	68.1	27.2	20.0	0.41
M151648	1.5	16	24.0	46.44	20.0	10	11	12.0	24.0	26.8	23.0	11.7	0.05
		48	72.0	27.27	50.0	12	33	12.0	20.0	73.0	17.0	10.0	0.33
M201545	2	15	30.0	60.00	25.3	8	15	14.0	28.9	35.4	28.9	14.2	0.09
		45	90.0	42.00	45.3	16	30	14.0	32.1	90.8	28.4	20.0	0.61
M201648	2	16	32.0	61.76	26.0	12	16	15.0	28.5	35.8	27.0	12.4	0.10
		48	96.0	32.90	60.0	15	40	15.0	23.0	97.3	19.0	10.0	0.65
M251545	2.5	15	37.5	73.00	32.3	12	18	18.0	34.6	44.2	34.6	15.9	0.13
		45	112.5	52.00	60.3	20	40	18.0	39.7	113.4	35.3	25.0	1.22
M251648	2.5	16	40.0	74.41	32.0	12	18	18.0	32.0	44.7	30.0	13.0	0.18
		48	120.0	38.60	70.0	20	48	18.0	26.0	121.6	21.0	10.0	1.13
M301545	3	15	45.0	88.00	40.3	16	22	21.0	41.3	53.0	41.3	19.7	0.34
		45	135.0	62.00	60.3	20	40	21.0	47.2	136.1	42.0	30.0	1.85
M301648	3	16	48.0	86.25	40.0	15	22	18.0	32.0	53.7	30.0	12.1	0.28
		48	144.0	45.20	80.0	20	54	18.0	29.0	145.9	23.0	10.0	1.85
M351545	3.5	15	52.5	105.00	45.3	20	28	23.5	49.6	61.9	49.6	25.0	0.60
		45	157.5	72.00	80.3	20	54	23.5	54.4	158.8	48.6	35.0	3.25
M351648	3.5	16	56.0	100.29	48.0	15	30	22.0	38.0	62.6	35.5	15.0	0.50
		48	168.0	49.48	90.0	20	60	22.0	31.0	170.2	24.0	10.0	2.69
M401545	4	15	60.0	117.00	50.3	20	32	27.5	54.3	70.7	54.3	25.4	0.75
		45	180.0	77.00	80.3	20	54	27.5	57.0	181.5	50.5	35.0	3.95
M401648	4	16	64.0	112.73	55.0	20	35	25.0	41.5	71.6	38.5	15.2	0.68
		48	192.0	54.20	100.0	20	66	25.0	33.0	194.5	25.0	10.0	3.74
M451545	4.5	15	67.5	128.00	55.3	20	36	28.5	55.2	79.5	55.2	24.8	0.87
		45	202.5	87.00	90.3	20	60	28.5	63.9	204.2	57.0	40.0	5.60
M451648	4.5	16	72.0	133.27	60.0	20	40	28.0	53.0	80.5	50.0	23.4	1.08
		48	216.0	72.93	100.0	20	66	28.0	49.0	218.8	40.0	18.0	6.70
M501545	5	15	75.0	145.00	60.3	20	40	33.0	65.3	88.4	65.3	30.0	1.35
		45	225.0	92.00	90.3	20	60	33.0	66.7	226.9	59.2	40.0	7.05
M501648	5	16	80.0	145.61	60.0	20	40	35.0	60.0	89.5	57.0	22.5	1.34
		48	240.0	75.45	150.0	20	100	35.0	50.0	243.2	40.0	20.0	9.00
Bevel Gear Sets 4 : 1 Ratio													
M101560	1	15	15.0	38.00	13.3	4	8	9.3	17.2	17.8	17.2	7.7	0.02
		60	60.0	22.00	30.3	8	20	9.3	17.1	60.3	15.2	10.0	0.24
M151560	1.5	15	22.5	57.00	20.3	8	11	11.0	23.0	26.7	23.0	11.7	0.04
		60	90.0	42.00	50.3	16	34	11.0	34.0	90.4	31.2	25.0	0.78
M151664	1.5	16	24.0	61.02	18.0	10	12	12.0	25.0	26.9	24.0	12.2	0.05
		64	96.0	30.53	70.0	15	48	12.0	22.0	96.7	19.0	10.0	0.71
M201560	2	15	30.0	75.00	25.3	8	14	16.0	31.0	35.6	31.0	14.4	0.12
		60	120.0	48.00	60.3	16	40	16.0	37.6	120.6	34.2	25.0	1.30
M201664	2	16	32.0	73.07	25.0	12	15	15.0	24.0	35.9	23.0	8.2	0.09
		64	128.0	35.79	80.0	20	54	15.0	24.0	129.0	20.0	10.0	1.23
M251560	2.5	15	37.5	94.00	32.3	14	20	19.0	38.1	44.5	38.1	18.4	0.21
		60	150.0	58.00	60.3	20	40	19.0	44.8	150.7	40.0	30.0	1.95
M251664	2.5	16	40.0	92.49	30.0	12	20	18.0	30.5	44.9	29.0	11.7	0.18
		64	160.0	42.77	90.0	20	60	18.0	29.0	161.2	24.0	10.0	2.38
M301560	3	15	45.0	115.00	40.3	16	24	23.0	48.1	53.3	48.1	24.5	0.40
		60	180.0	69.00	80.3	20	54	23.0	53.2	180.8	48.2	35.0	3.65
M301664	3	16	48.0	108.05	40.0	15	25	22.0	34.0	53.8	32.0	11.0	0.32
		64	192.0	46.41	100.0	20	66	22.0	30.0	193.5	24.0	10.0	3.43
M351560	3.5	15	52.5	131.00	45.3	20	30	26.0	52.1	62.6	52.1	25.1	0.56
		60	210.0	79.00	90.3	20	60	26.0	60.4	211	54.4	40.0	5.40
M351664	3.5	16	56.0	132.13	48.0	15	32	25.0	45.0	62.8	43.0	19.1	0.60
		64	224.0	69.32	100.0	20	66	25.0	50.0	225.7	43.0	22.0	7.00
M401560	4	15	60.0	145.00	50.3	20	34	30.0	55.1	71.1	55.1	23.0	0.79
		60	240.0	82.00	90.3	20	60	30.0	60.8	241.1	53.0	40.0	6.20
M401664	4	16	64.0	148.21	50.0	20	34	30.0	50.0	71.8	48.0	18.5	0.79
		64	256.0	71.72	120.0	20	80	30.0	50.0	257.9	42.0	20.0	9.60
M451560	4.5	15	67.5	159.90	52.3	20	35	32.0	57.0	79.97	57.0	23.0	1.08
		60	270.0	86.30	90.3	20	60	32.0	62.0	271.2	53.5	40.0	7.95
M451664	4.5	16	72.0	165.08	55.0	20	38	32.0	53.0	80.7	50.5	19.0	1.07
		64	288.0	77.83	130.0	20	84	32.0	53.0	290.2	44.0	23.0	12.00
M501560	5	15	75.0	177.70	55.3	20	36	34.0	62.0	88.8	62.0	25.0	1.40
		60	300.0	92.00	90.3	20	60	34.0	65.0	301.3	55.0	40.0	10.30
M501664	5	16	80.0	183.06	60.0	20	40	35.0	58.0	89.7	55.5	20.6	1.46
		64	320.0	85.65	150.0	20	100	35.0	58.0	322.4	48.0	25.0	16.50

All dimensions in mm.

All gears stocked with standard plain bore. Rebore, keyway, setscrew and induction hardening services available.

Bevel and mitre gears with other D.P. and module can be supplied to order up to 375mm diameter.

Tel +44 121 360 0155

Fax +44 121 325 1079

Email sales@crossmorse.com